

DO NOT SCALE
IF IN DOUBT ASK

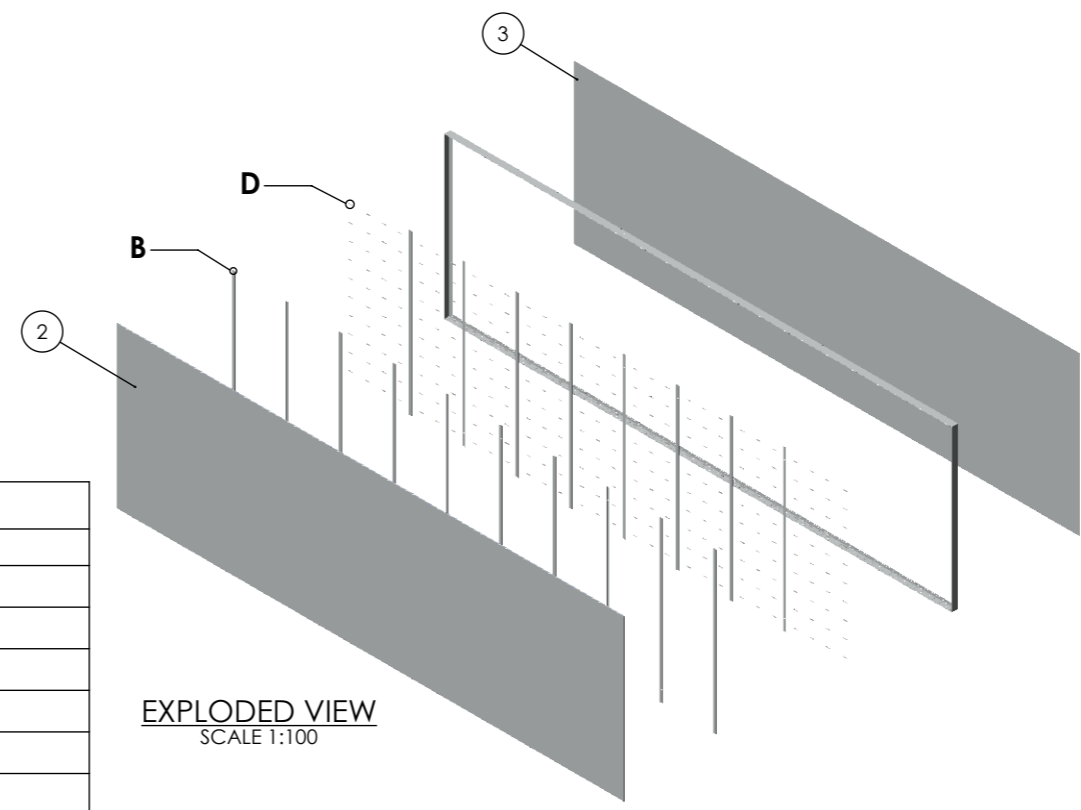
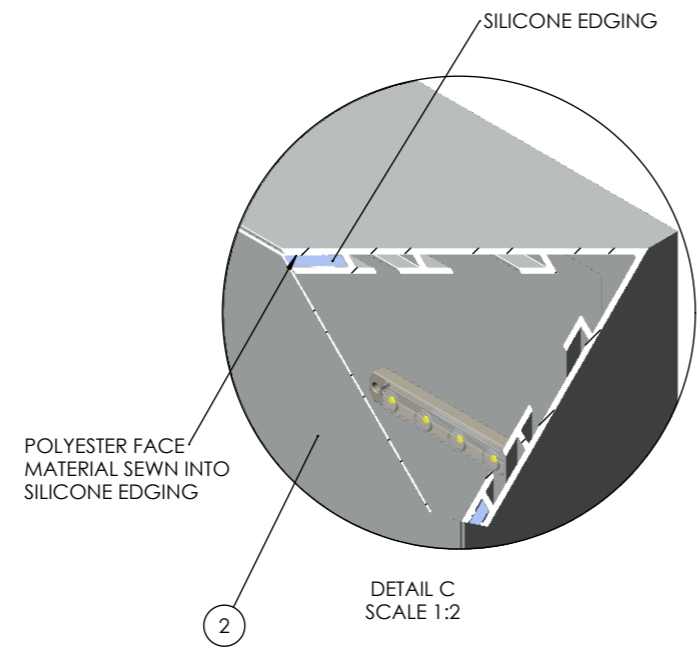
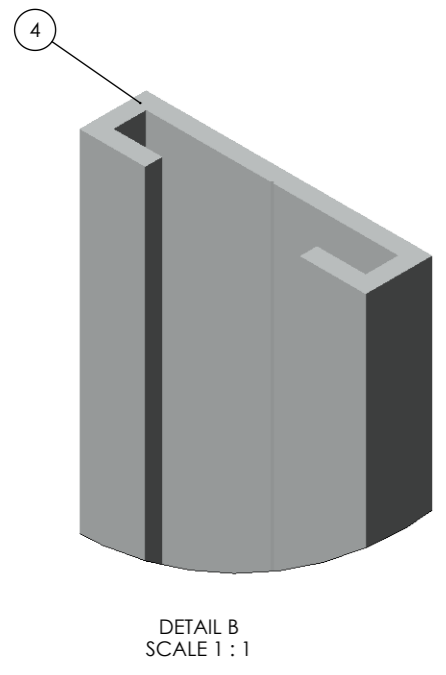
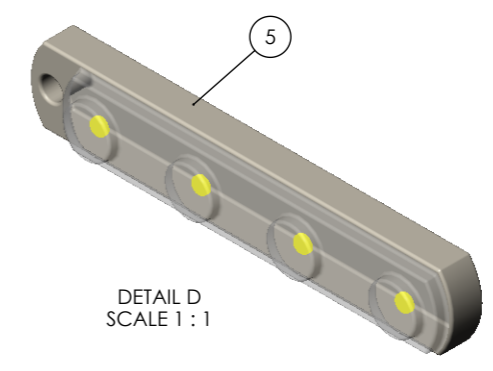
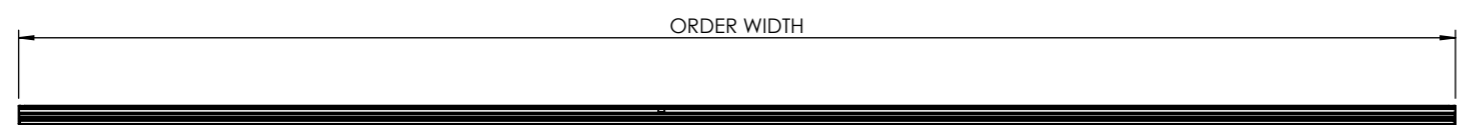
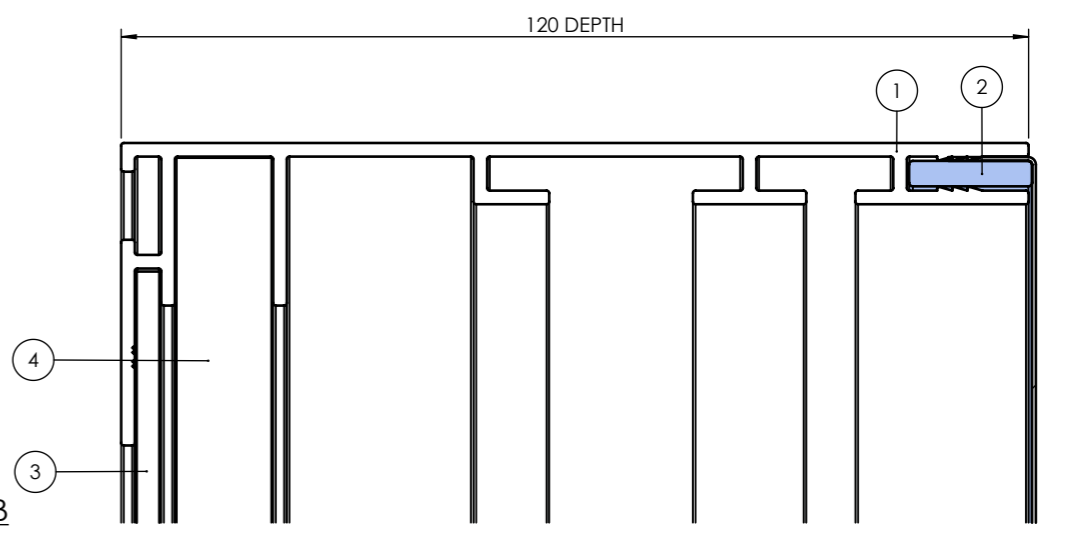
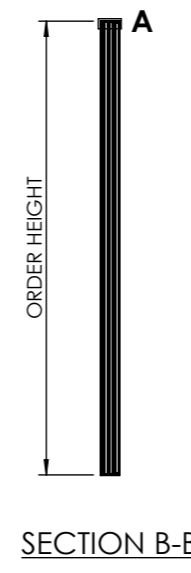
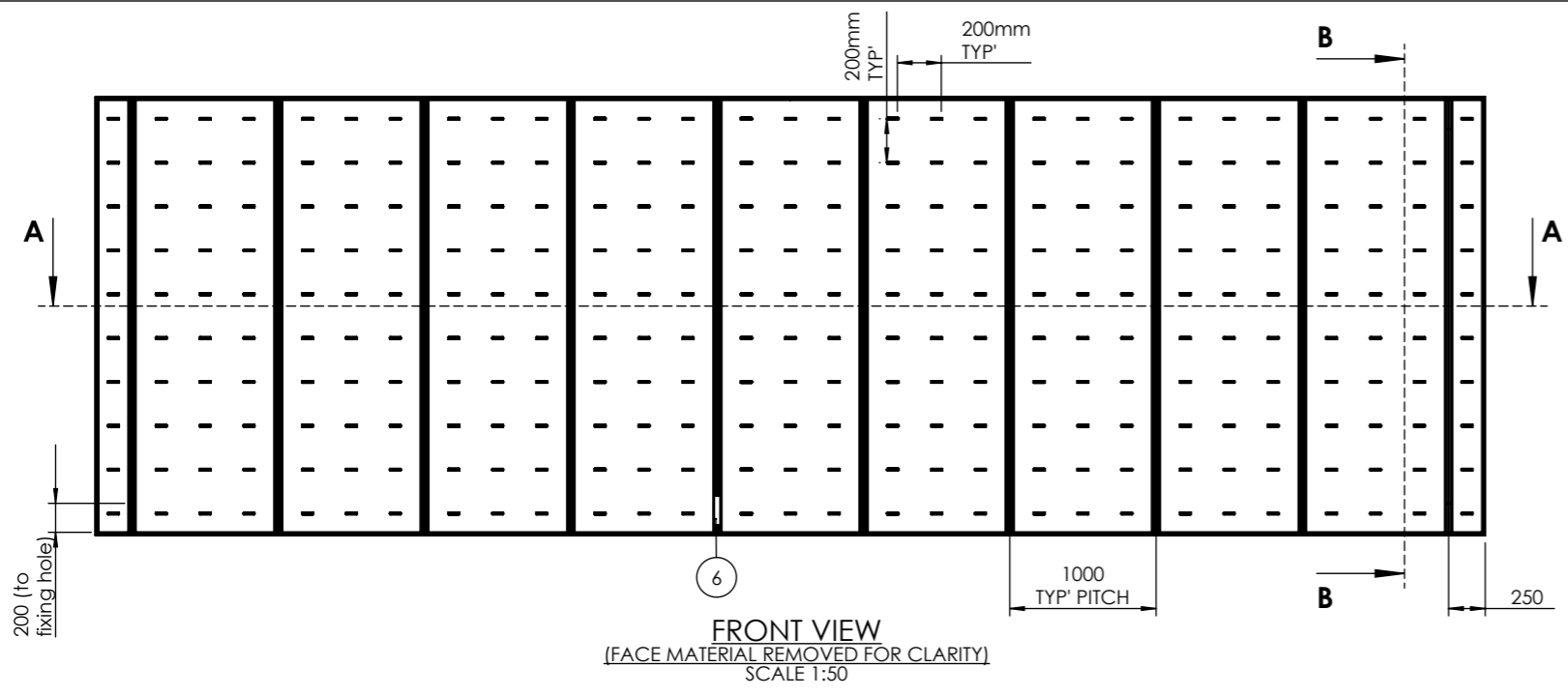

REV.	DATE	DESCRIPTION	BY

THIS DRAWING IS THE PROPERTY OF KSUK LTD AND MAY NOT BE REPRODUCED OR TRANSMITTED IN ANY FORM OR BY ANY MEANS, ELECTRONIC OR MECHANICAL, WITHOUT THE EXPRESS WRITTEN CONSENT OF THE COMPANY. IT IS TO BE USED FOR ANY OTHER PURPOSE THAN THAT FOR WHICH IT IS SUPPLIED.

GENERAL TOLERANCES UNLESS OTHERWISE STATED:
0 DECIMAL PLACES +/- 1mm
1 DECIMAL PLACE +/- 0.5mm
2 DECIMAL PLACES +/- 0.15mm
ANGULAR DIMENSIONS +/- 1/2°

KSUK[®]

T 0121 783 0779, F 0121 783 1334
KSUK, Unit 6 Valepits Road, Garrets Green Industrial Estate, Birmingham, West Midlands, B33 0TD

DRAWING TITLE: TEXFLEX 120	
PRODUCT RANGE: TEXFLEX	
PROJECT No: IDS-236	DATE: 17-02-19
PAPER: A3	DRAWN: R.L CHKD: -
SCALE: N.T.S	DWG No.: IDS-236-024 REV: -

BILL OF MATERIALS TEXFLEX 120

ITEM NO.	DRAWING No/REF	QTY	FINISH	NOTES
1	TEXFLEX 120 PROFILE	1		
2	SILICONE KEDER WITH POLYESTER FACE	1		
3	BACKING	1		1-3mm THICKNESS RANGE
4	TEXFLEX 120 WALL SUPPORT	AS REQ'		1000mm PITCH TYPICALLY
5	GE MODULE	AS REQ'		200mm GRID FORMATION
6	LED CONVERTER	1		