

DO NOT SCALE
IF IN DOUBT ASK

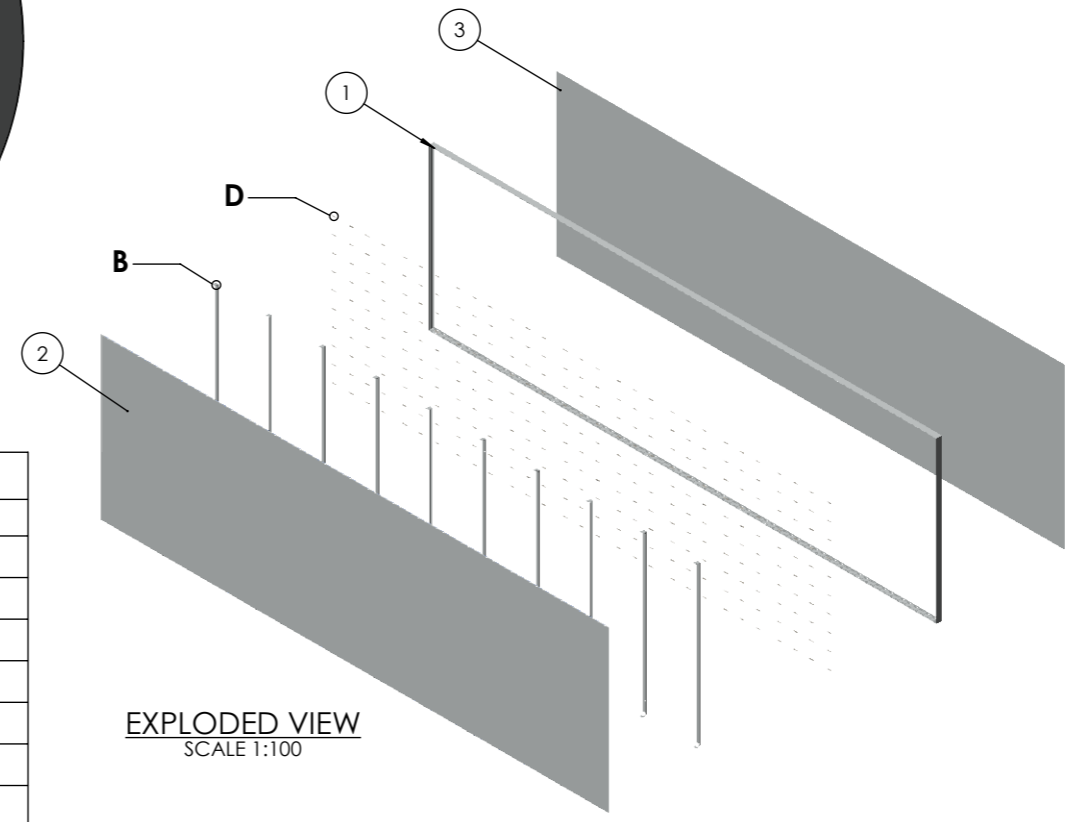
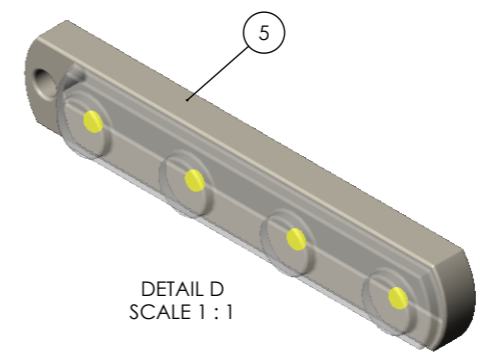
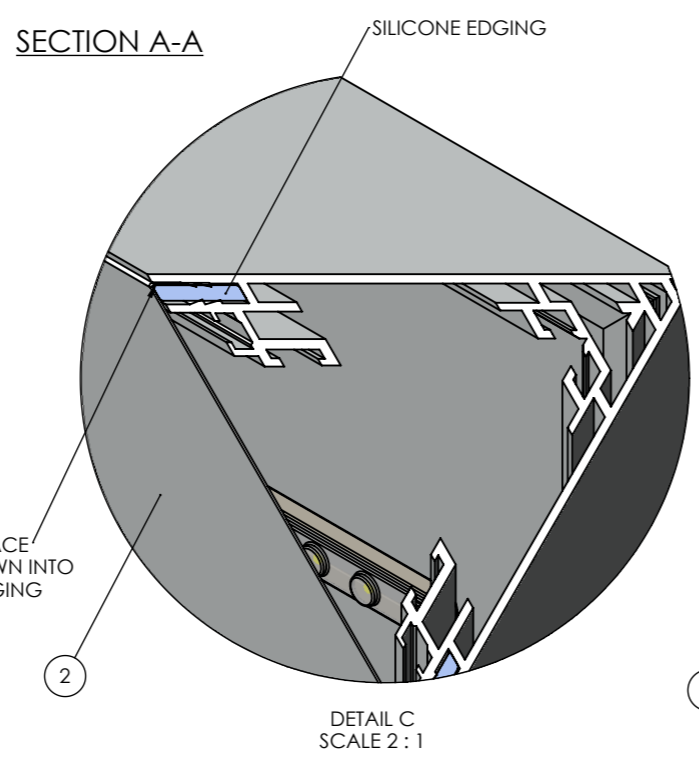
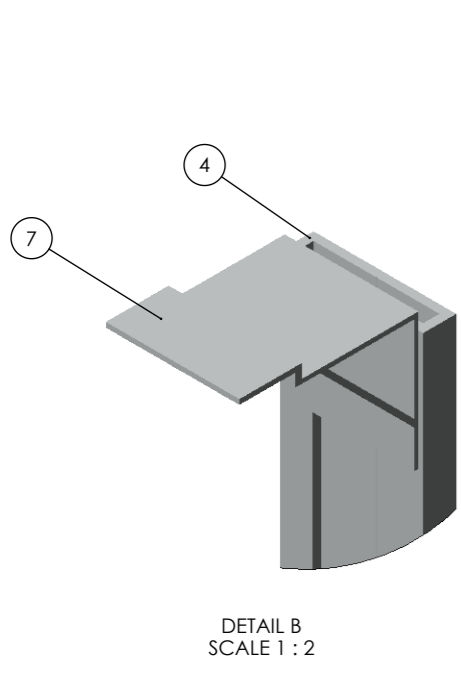
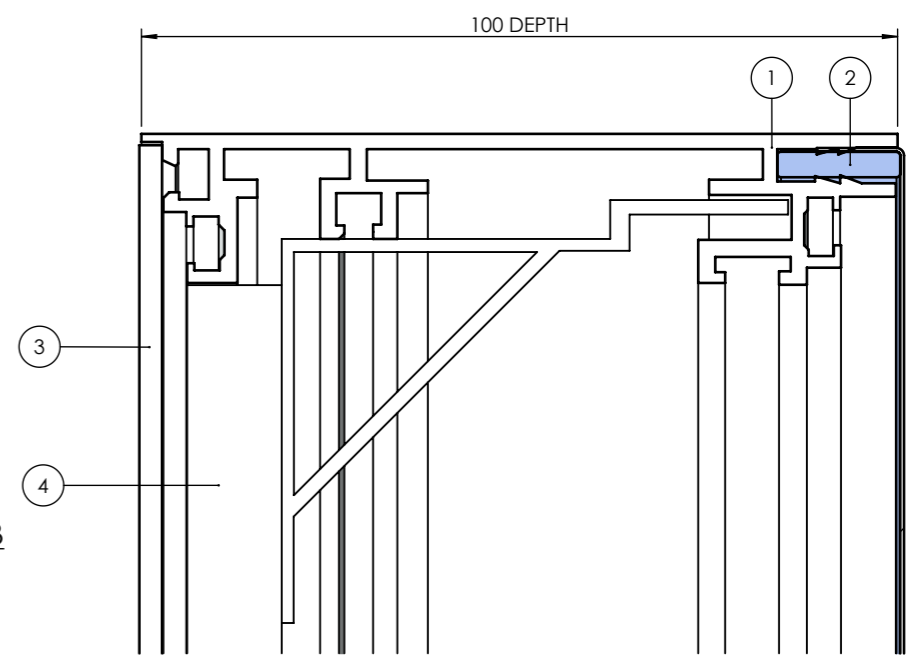
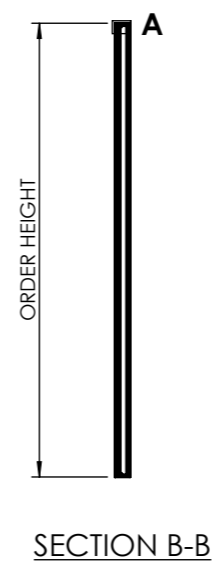
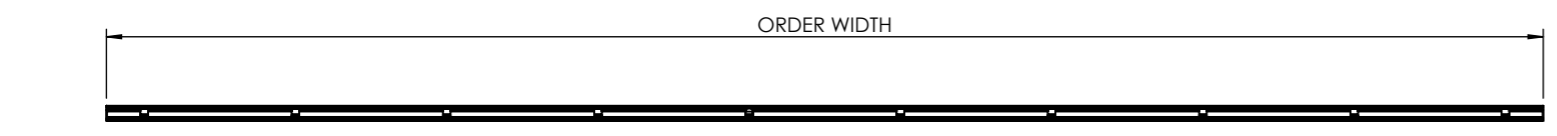
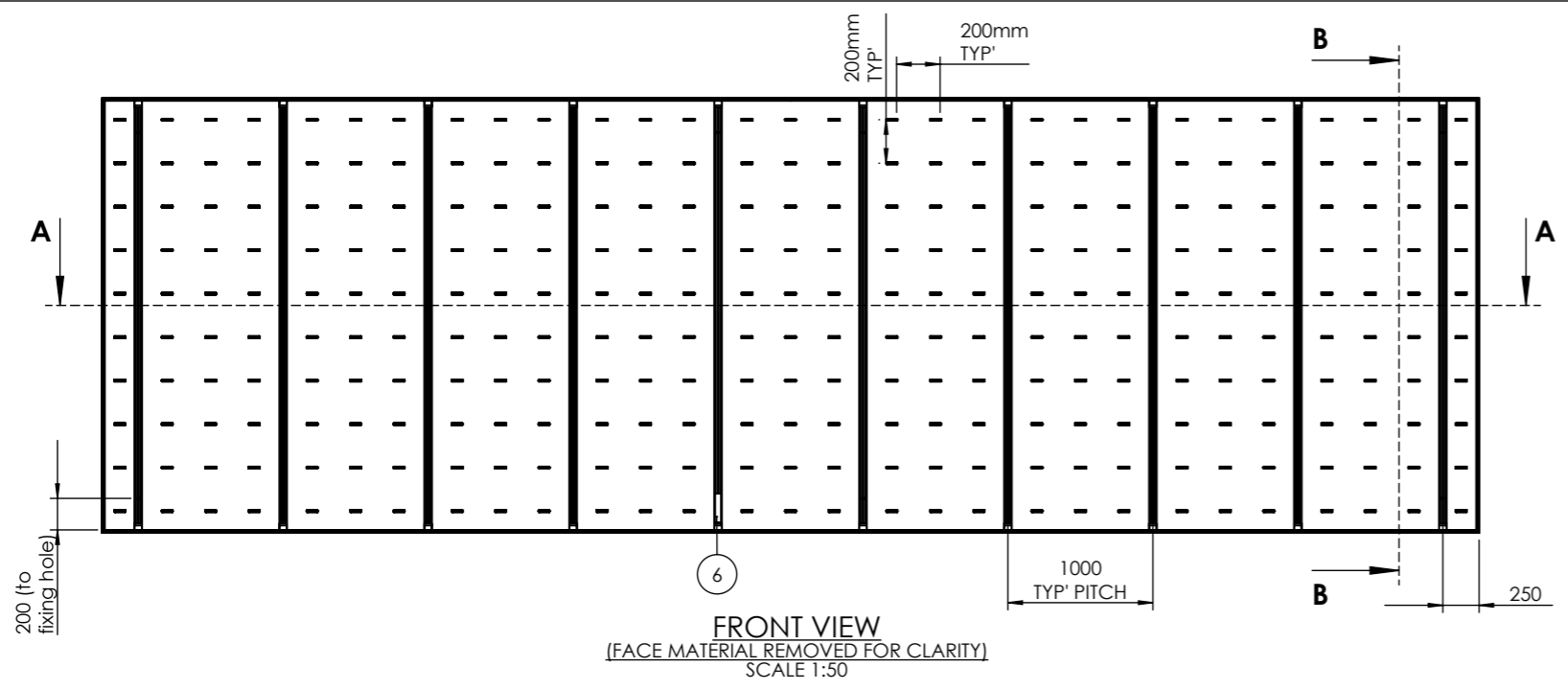

REV.	DATE	DESCRIPTION	BY

THIS DRAWING IS THE PROPERTY OF KSUK LTD AND MAY NOT BE COPIED IN WHOLE OR IN PART OR USED FOR ANY OTHER PURPOSE THAN THAT FOR WHICH IT IS SUPPLIED

GENERAL TOLERANCES UNLESS OTHERWISE STATED:
 0 DECIMAL PLACES +/- 1mm
 1 DECIMAL PLACE +/- 0.5mm
 2 DECIMAL PLACES +/- 0.15mm
 ANGULAR DIMENSIONS +/- 1/2°

BILL OF MATERIALS TEXFLEX 100				
ITEM NO.	DRAWING No/REF	QTY	FINISH	NOTES
1	TEXFLEX 100 PROFILE	1		
2	SILICONE KEDER WITH POLYESTER FACE	1		
3	BACKING	1		1-3mm THICKNESS RANGE
4	TEXFLEX 100 WALL SUPPORT	AS REQ'		1000mm PITCH TYPICALLY
5	GE MODULE	AS REQ'		200mm GRID FORMATION
6	LED CONVERTER	1		
7	TEXFLEX 100 SUPPORT BRACE	2 PER WALL SUPPORT		

KSUK[®]

T 0121 783 0779, F 0121 783 1334

KSUK, Unit 6 Valepits Road, Garrets Green Industrial Estate, Birmingham, West Midlands, B33 0TD

DRAWING TITLE: **TEXFLEX 100**

PRODUCT RANGE: **TEXFLEX**

PROJECT No: **IDS-236** DATE: **22-02-19**

PAPER: **A3** DRAWN: **R.L** CHKD: **-**

SCALE: **N.T.S** DWG No.: **IDS-236-023** REV: **-**