

DO NOT SCALE
IF IN DOUBT ASK

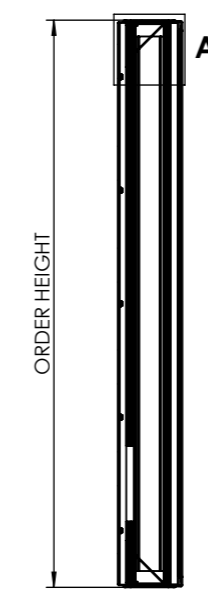

SECTION A-A

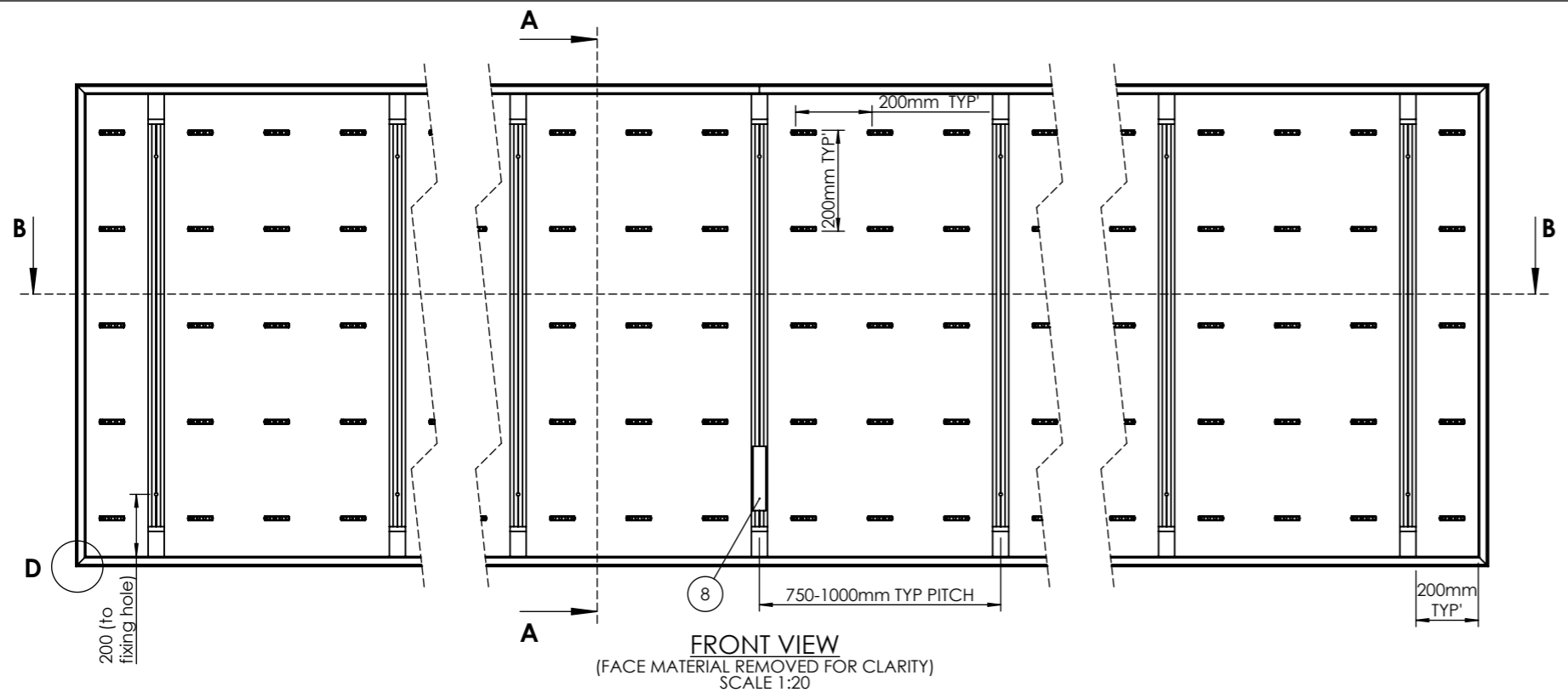
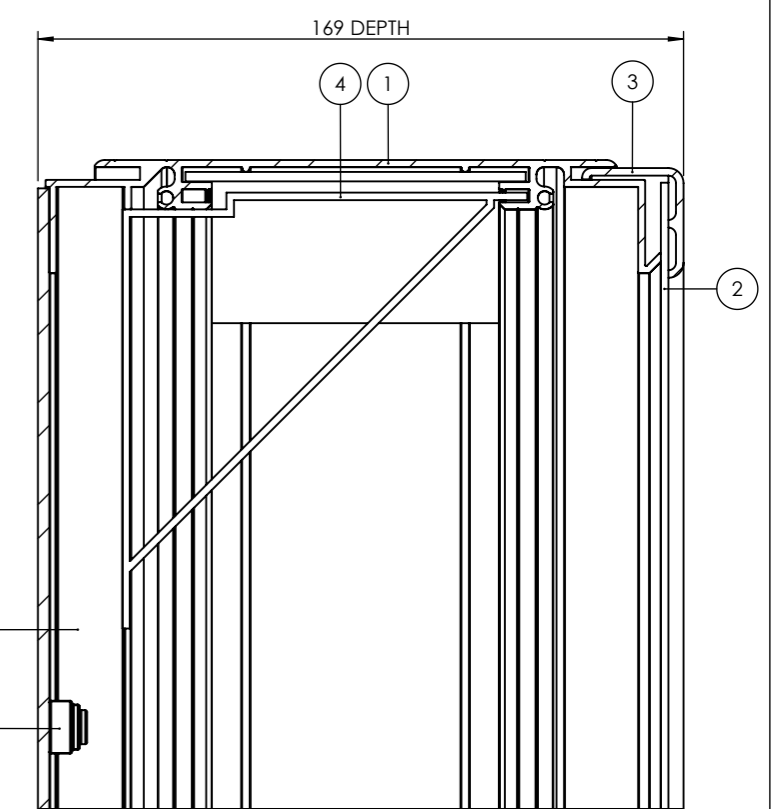

DETAIL A
SCALE 1 : 2

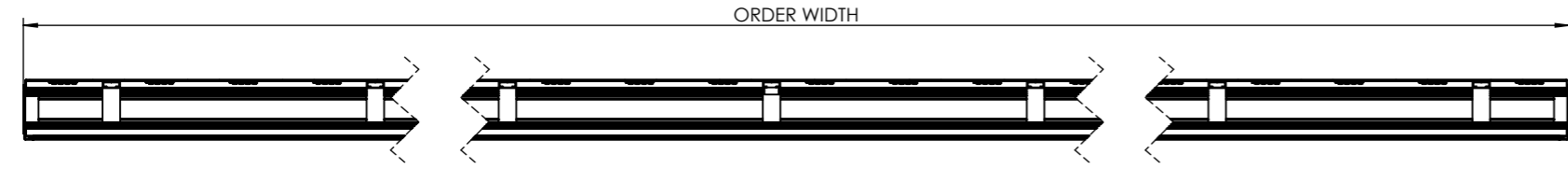

SECTION B-B

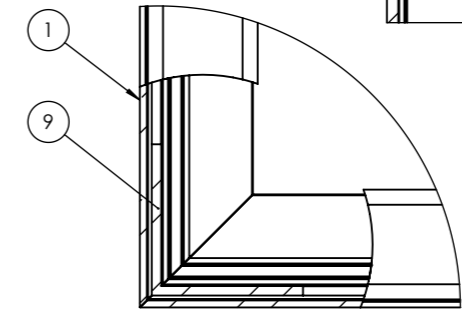

DETAIL D
(BROKEN-OUT SECTION TO SHOW ITEM 9)
SCALE 1 : 2

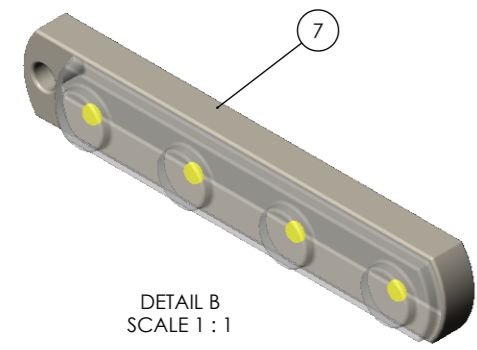

DETAIL B
SCALE 1 : 1

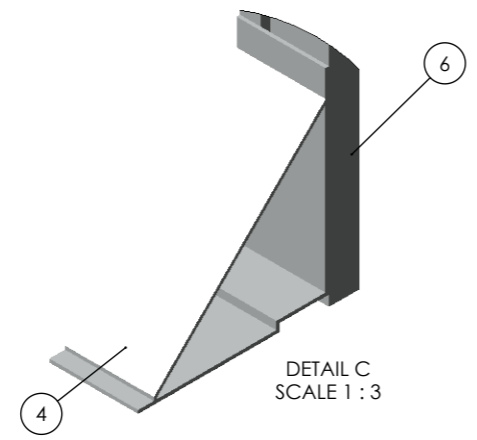

DETAIL C
SCALE 1 : 3

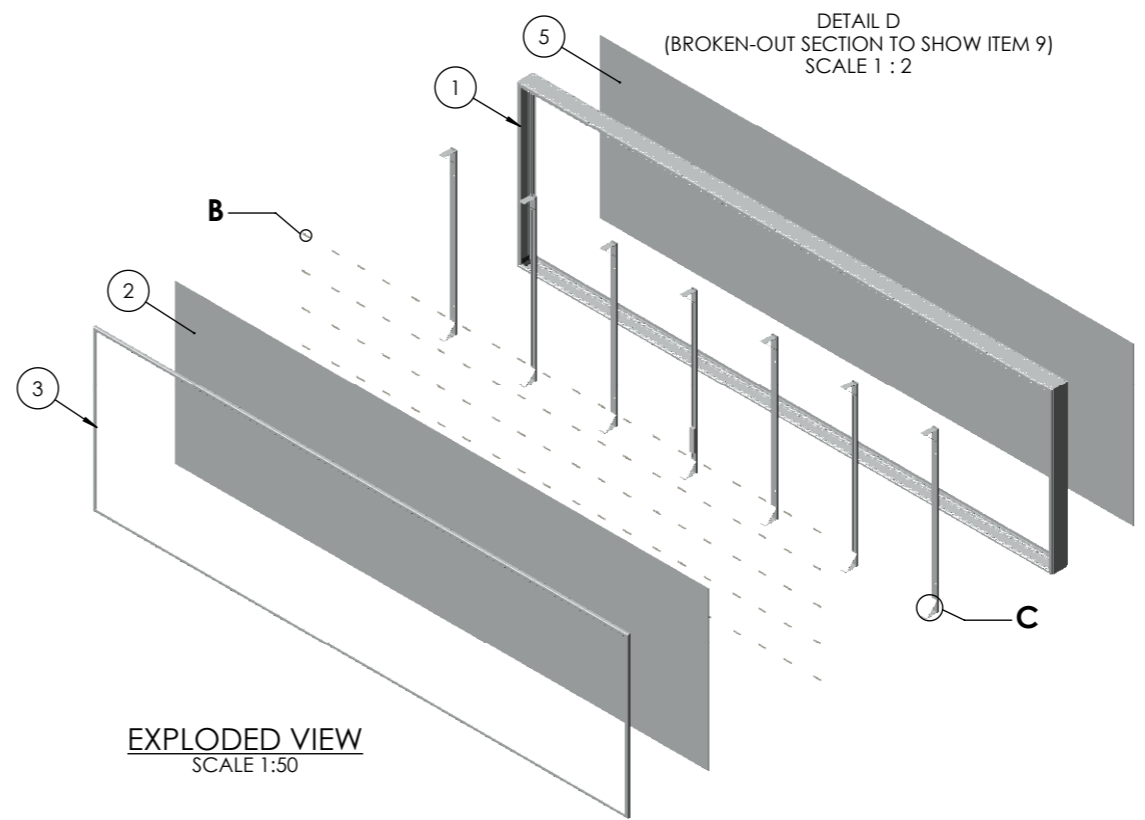

EXPLODED VIEW
SCALE 1:50

BILL OF MATERIALS SIGNCASE 160

ITEM NO.	DRAWING No/REF	QTY	FINISH	NOTES
1	SIGNCASE 160 FRAME	1		
2	ACRYLIC SHEET	1		3-5mm THICKNESS RANGE
3	SIGNCASE 160 BEAD	1		
4	OPTIONAL BRACE REF TBC	AS REQ'		
5	BACKPLATE	1		1-3mm THICKNESS RANGE
6	WALL BAR REF TBC	AS REQ'		750-1000mm PITCH TYPICALLY
7	LED MODULE ASSEMBLY	AS REQ'		200mm GRID FORMATION
8	LED CONVERTER	1		
9	CORNER ANGLE	4		

REV.	DATE	DESCRIPTION	BY

THIS DRAWING IS THE PROPERTY OF KSUK LTD AND MAY NOT BE COPIED IN WHOLE OR IN PART OR USED FOR ANY OTHER PURPOSE THAN THAT FOR WHICH IT IS SUPPLIED

GENERAL TOLERANCES UNLESS OTHERWISE STATED
 0 DECIMAL PLACES +/- 1mm
 1 DECIMAL PLACE +/- 0.5mm
 2 DECIMAL PLACES +/- 0.15mm
 ANGULAR DIMENSIONS +/- 1/2°

KSUK®

T 0121 783 0779, F 0121 783 1334
 KSUK, Unit 6 Valepits Road, Garrets Green Industrial Estate, Birmingham, West Midlands, B33 0TD

DRAWING TITLE: SIGNCASE 160

PRODUCT RANGE: SIGNCASE

PROJECT No: IDS-236 DATE: 04-01-19

PAPER: A3 DRAWN: R.L. CHKD: -

SCALE: N.T.S DWG No.: IDS-236-008 REV: -