

DO NOT SCALE  
IF IN DOUBT ASK

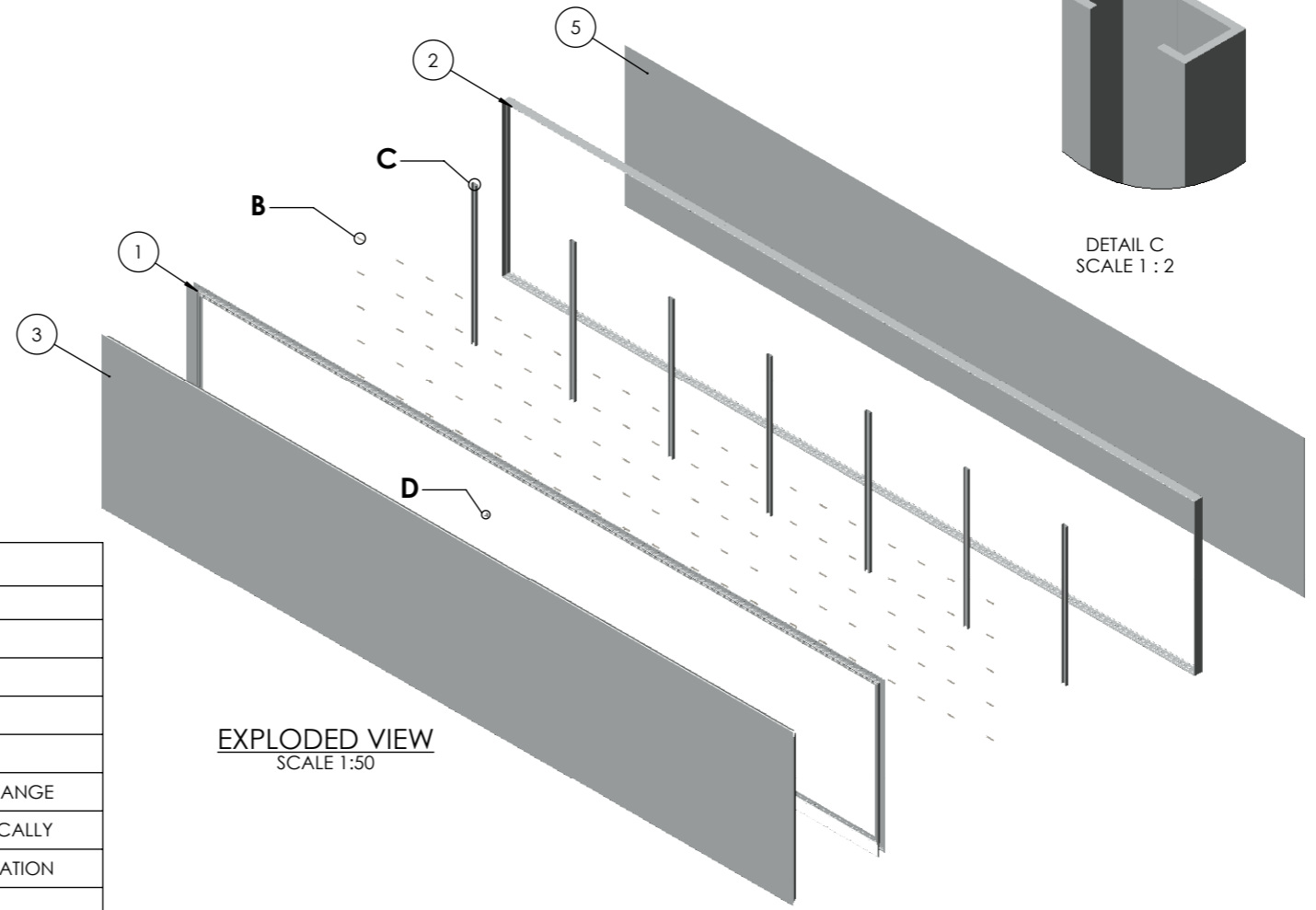
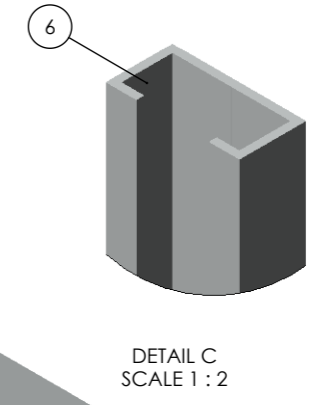
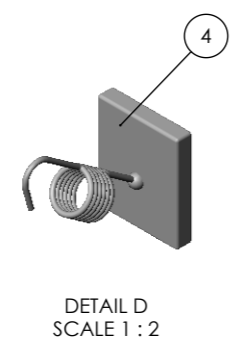
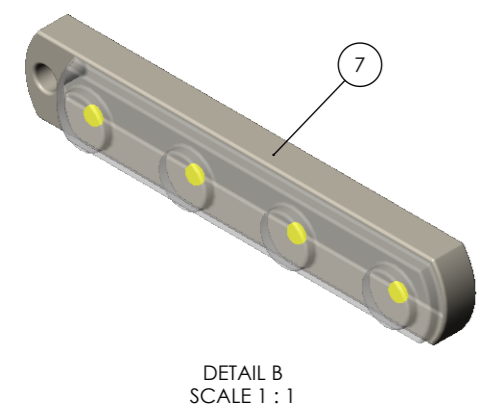
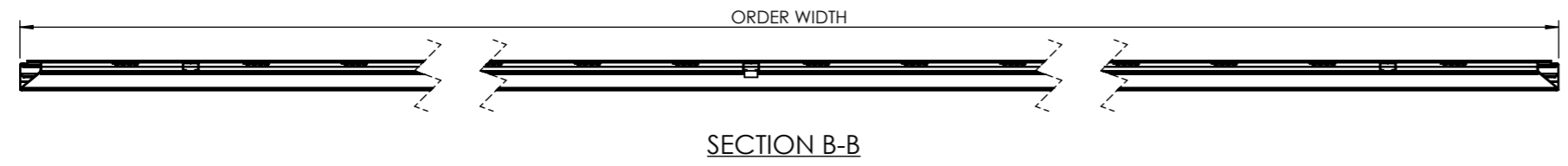
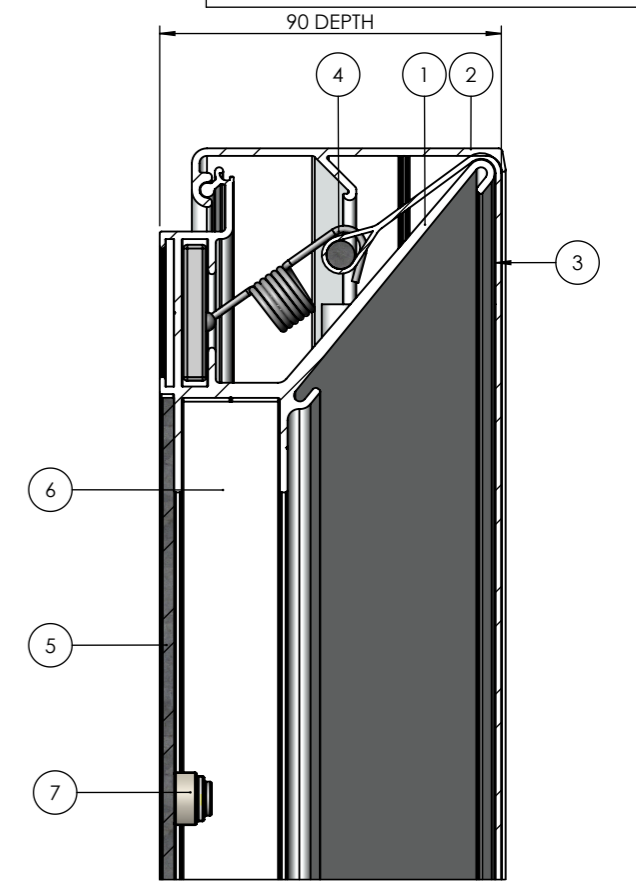
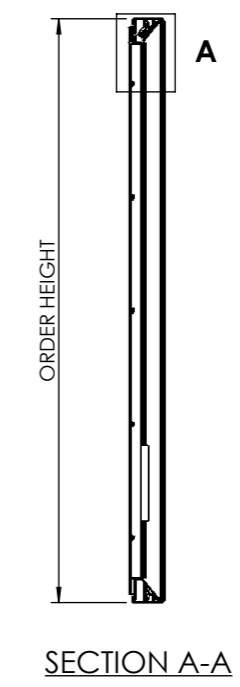
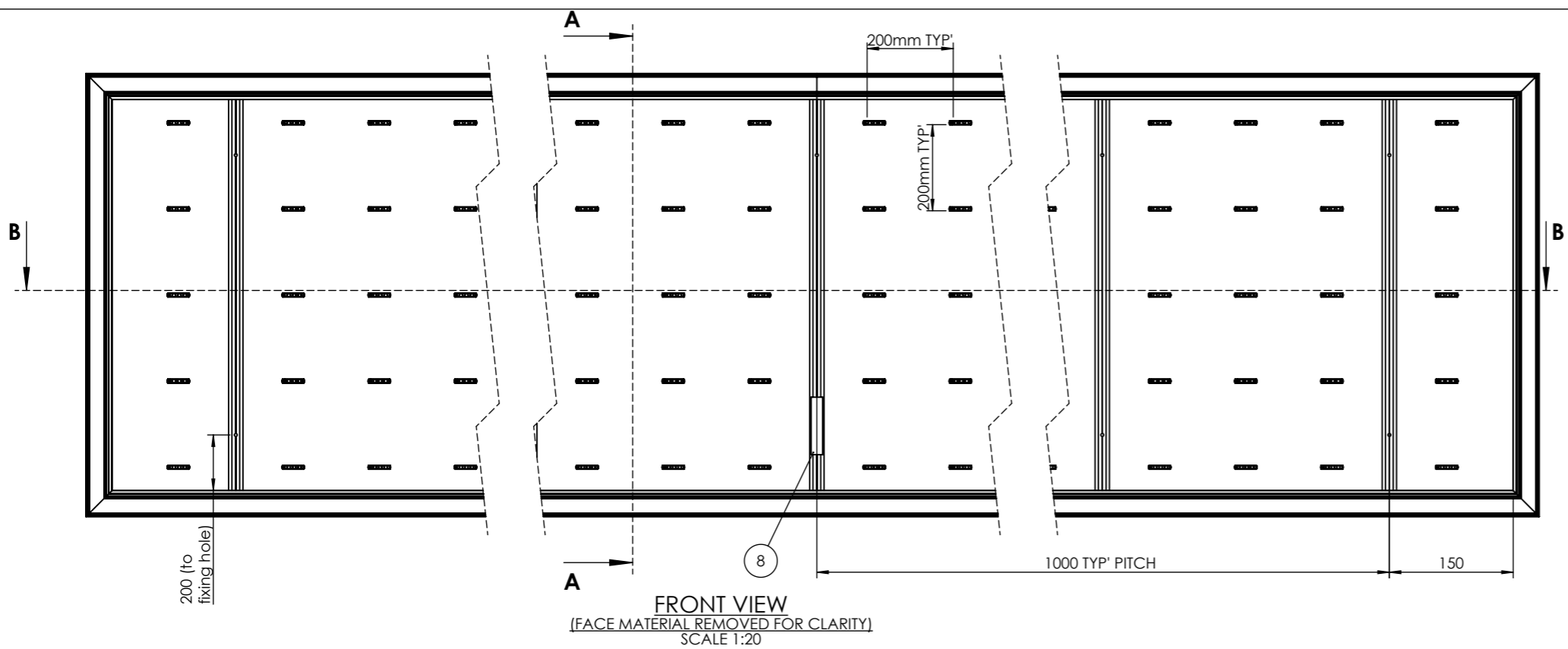

BILL OF MATERIALS SPRINGFLEX 90				
ITEM NO.	DRAWING No/REF	QTY	FINISH	NOTES
1	90 PROFILE SF2590M	1		
2	90 LID SF2644	1		
3	FACE MATERIAL - 90	1		
4	SF2601 TENSION SPRING	AS REQ'		
5	BACKPLATE	1		1-3mm THICKNESS RANGE
6	WALL BAR SF1577M	AS REQ'		1000mm PITCH TYPICALLY
7	GE MODULE	AS REQ'		200mm GRID FORMATION
8	LED CONVERTER	1		

REV. DATE	DESCRIPTION	BY
A 29-11-18	GE MODULE INCLUDED	R.L
<p>THIS DRAWING IS THE PROPERTY OF KSUK LTD AND MAY NOT BE REPRODUCED OR TRANSMITTED IN ANY FORM OR BY ANY MEANS, ELECTRONIC OR MECHANICAL, INCLUDING PHOTOCOPYING, RECORDING, OR BY ANY INFORMATION STORAGE AND RETRIEVAL SYSTEM, WITHOUT THE EXPRESS WRITTEN CONSENT OF THE COMPANY. ANY UNAUTHORIZED USE OF THIS DRAWING FOR ANY OTHER PURPOSE THAN THAT FOR WHICH IT IS SUPPLIED IS PROHIBITED.</p> <p>GENERAL TOLERANCES UNLESS OTHERWISE STATED: 0 DECIMAL PLACES +/- 1mm 1 DECIMAL PLACE +/- 0.5mm 2 DECIMAL PLACES +/- 0.15mm ANGULAR DIMENSIONS +/- 1/2°</p>		
<h1>KSUK®</h1> <p>T 0121 783 0779, F 0121 783 1334 KSUK, Unit 6 Valepits Road, Garrets Green Industrial Estate, Birmingham, West Midlands, B33 0TD</p>		
DRAWING TITLE: SPRINGFLEX 90		
PRODUCT RANGE: SPRINGFLEX		
PROJECT No: IDS-236	DATE: 21-11-18	
PAPER: A3	DRAWN: R.L	CHKD: -
SCALE: N.T.S	DWG No.: IDS-236-003	REV: A