

DO NOT SCALE
IF IN DOUBT ASK

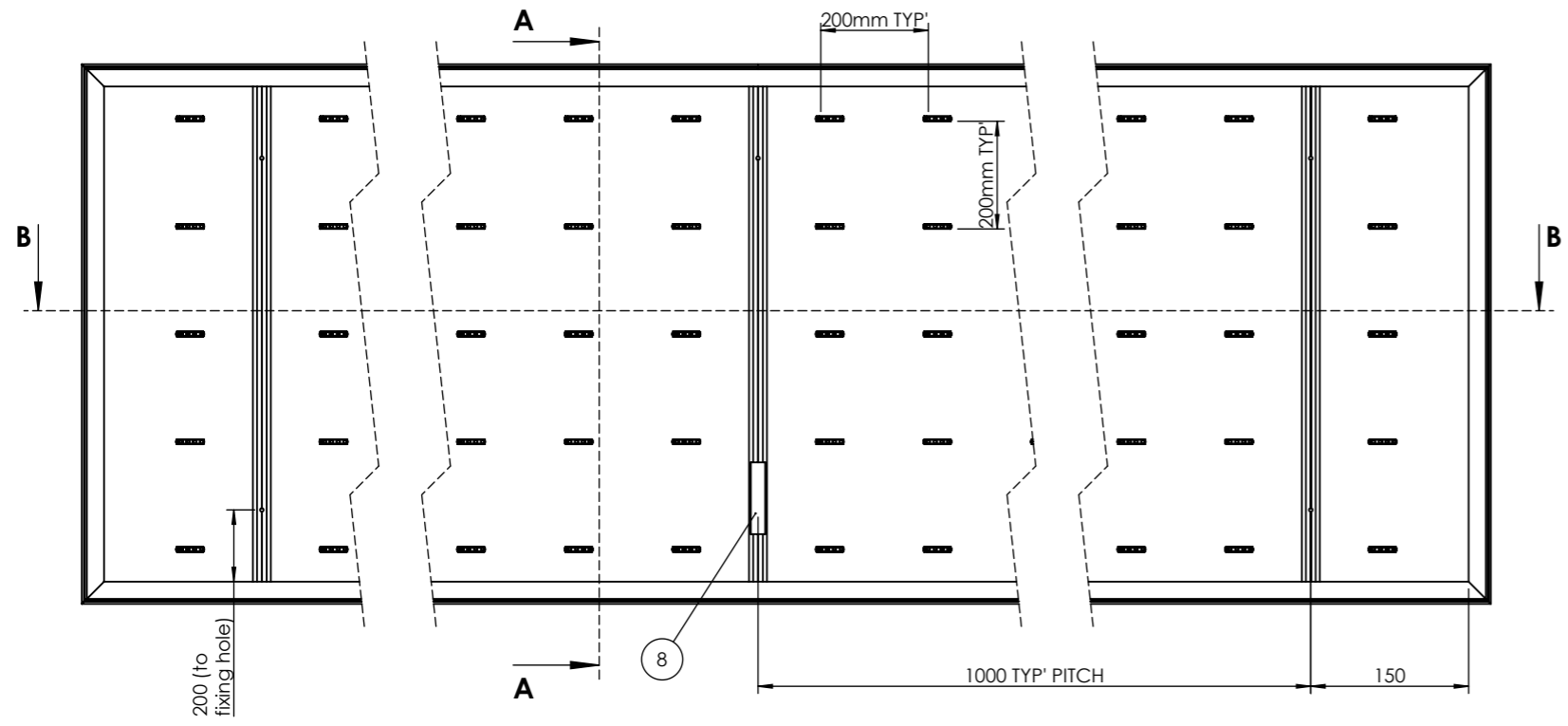

FRONT VIEW
(FACE MATERIAL REMOVED FOR CLARITY)
SCALE 1:20

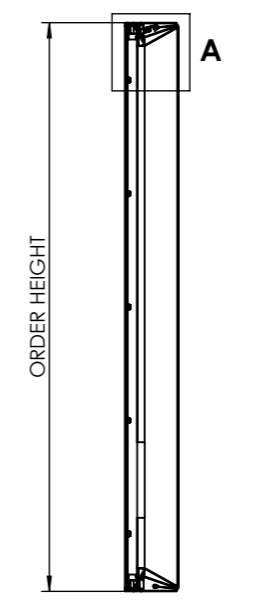

SECTION A-A

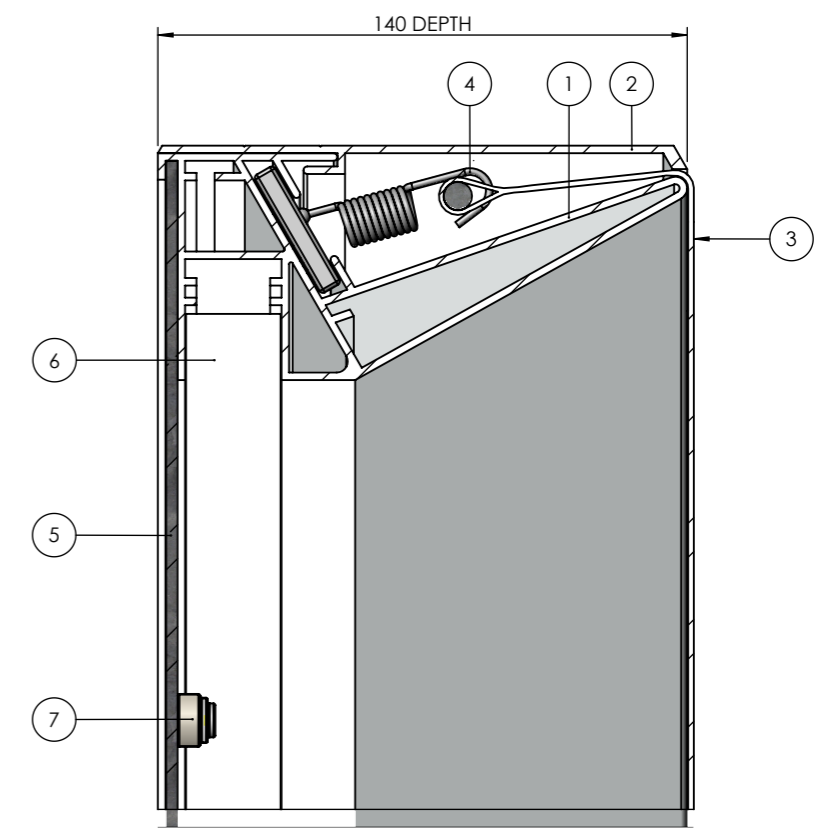

DETAIL A
SCALE 1:2

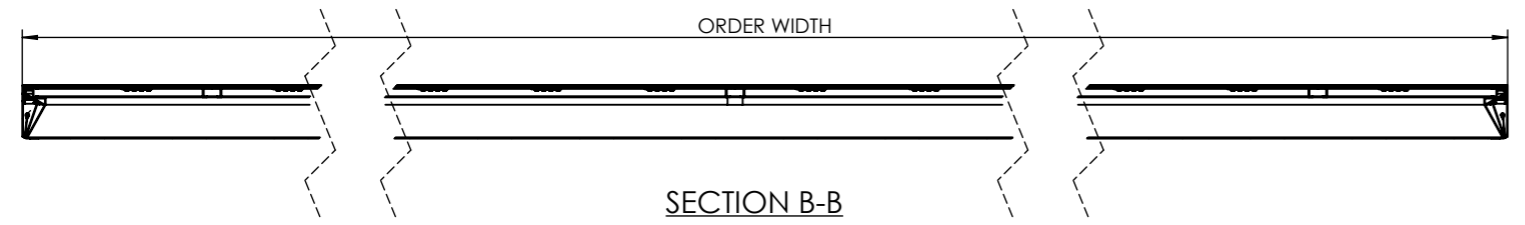

SECTION B-B

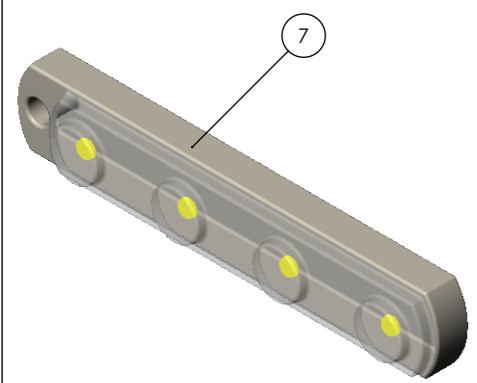

DETAIL B
SCALE 1:1

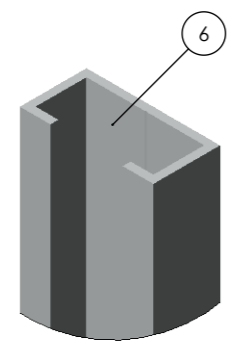

DETAIL C
SCALE 1:2

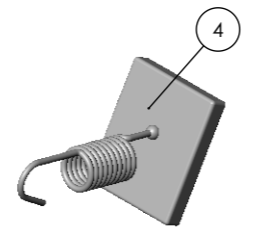

DETAIL D
SCALE 1:2

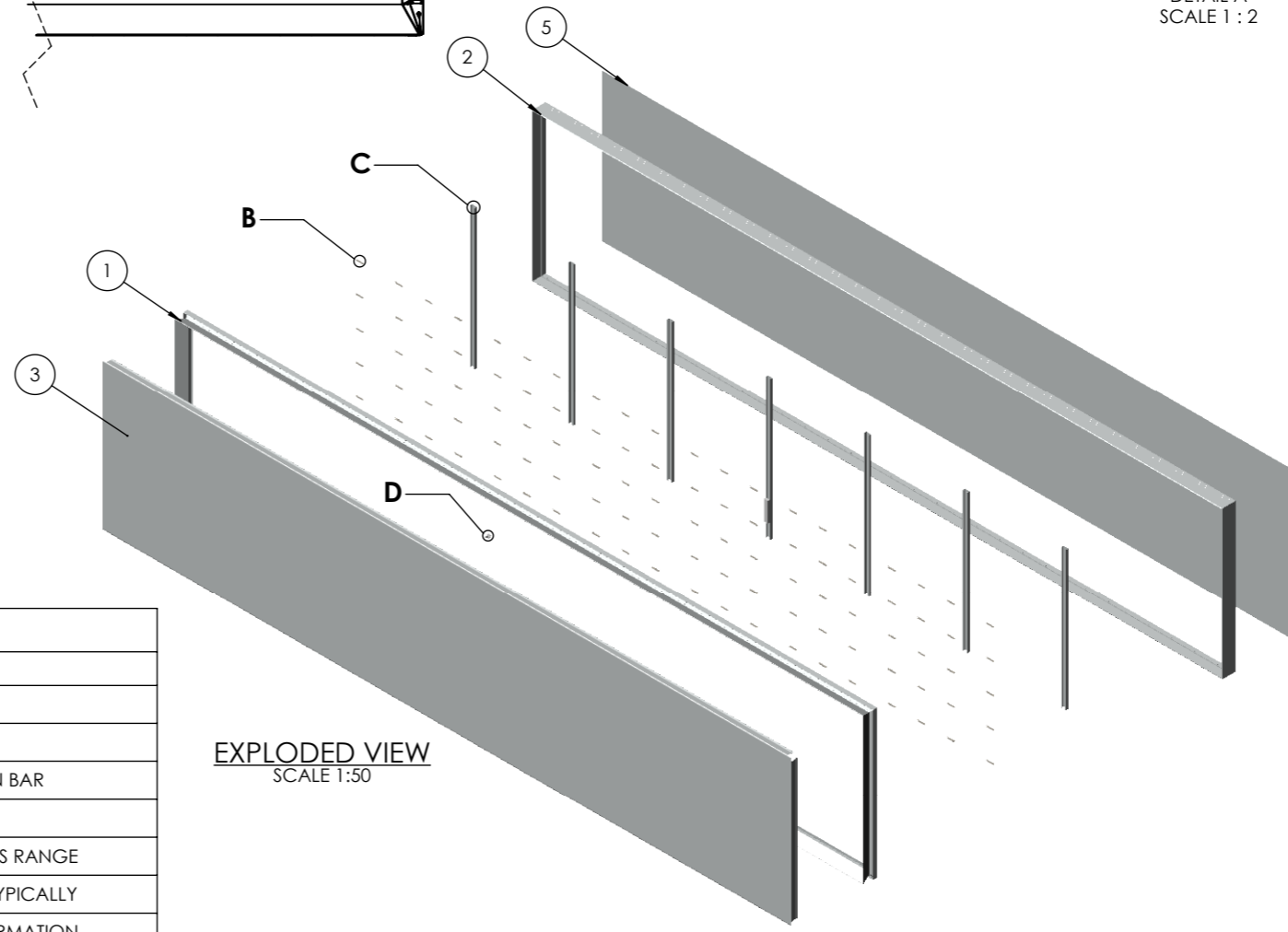

EXPLODED VIEW
SCALE 1:50

REV. DATE	DESCRIPTION	BY
A 29-11-18	GE MODULE INCLUDED	R.L
<small>THIS DRAWING IS THE PROPERTY OF KSUK LTD AND MAY NOT BE REPRODUCED OR TRANSMITTED IN ANY FORM OR BY ANY MEANS WITHOUT THE EXPRESS WRITTEN CONSENT OF THE COMPANY BEING COPIED IN WHOLE OR IN PART OR USED FOR ANY OTHER PURPOSE THAN THAT FOR WHICH IT IS SUPPLIED</small>		
<small>GENERAL TOLERANCES UNLESS OTHERWISE STATED: 0 DECIMAL PLACES +/- 1mm 1 DECIMAL PLACE +/- 0.5mm 2 DECIMAL PLACES +/- 0.15mm ANGULAR DIMENSIONS +/- 1/2°</small>		

BILL OF MATERIALS SPRINGFLEX 140				
ITEM NO.	DRAWING No/REF	QTY	FINISH	NOTES
1	BODY SF1582M	1		
2	COVER SF1552	1		
3	FACE MATERIAL	1		C/W TENSION BAR
4	SPRING ASS SF2001	1		
5	BACKPLATE	1		1-3mm THICKNESS RANGE
6	WALL BAR SF1577M	AS REQ'		1000mm PITCH TYPICALLY
7	GE MODULE	AS REQ'		200mm GRID FORMATION
8	LED CONVERTER	1		



T 0121 783 0779, F 0121 783 1334
KSUK, Unit 6 Valepits Road, Garrets Green Industrial Estate, Birmingham, West Midlands, B33 0TD

DRAWING TITLE: SPRINGFLEX 140		
PRODUCT RANGE: SPRINGFLEX		
PROJECT No: IDS-236	DATE: 07-11-18	
PAPER: A3	DRAWN: R.L	CHKD: -
SCALE: N.T.S	DWG No.: IDS-236-001	REV: A