

DO NOT SCALE
IF IN DOUBT ASK

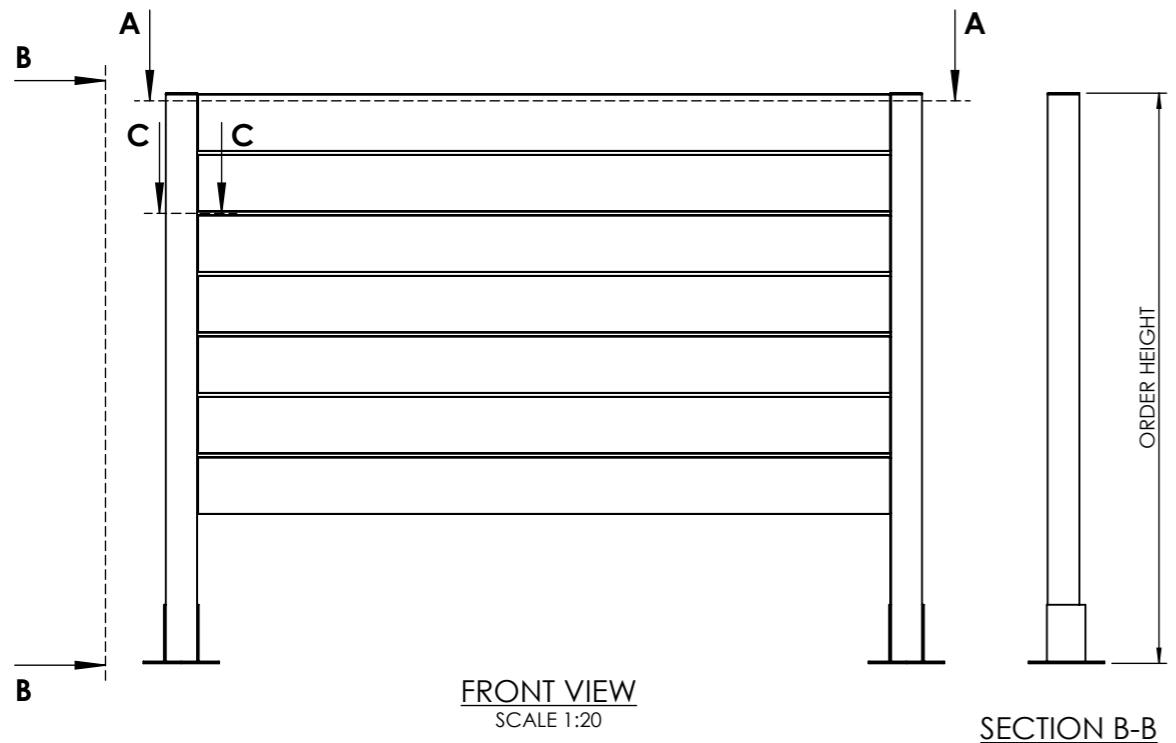

FRONT VIEW
SCALE 1:20

SECTION B-B

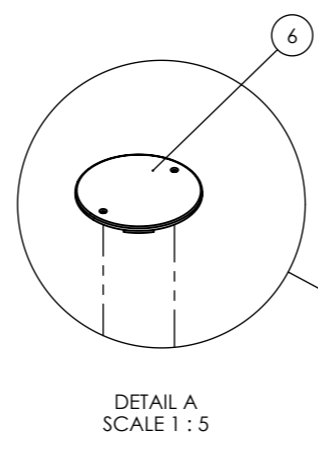

DETAIL A
SCALE 1:5

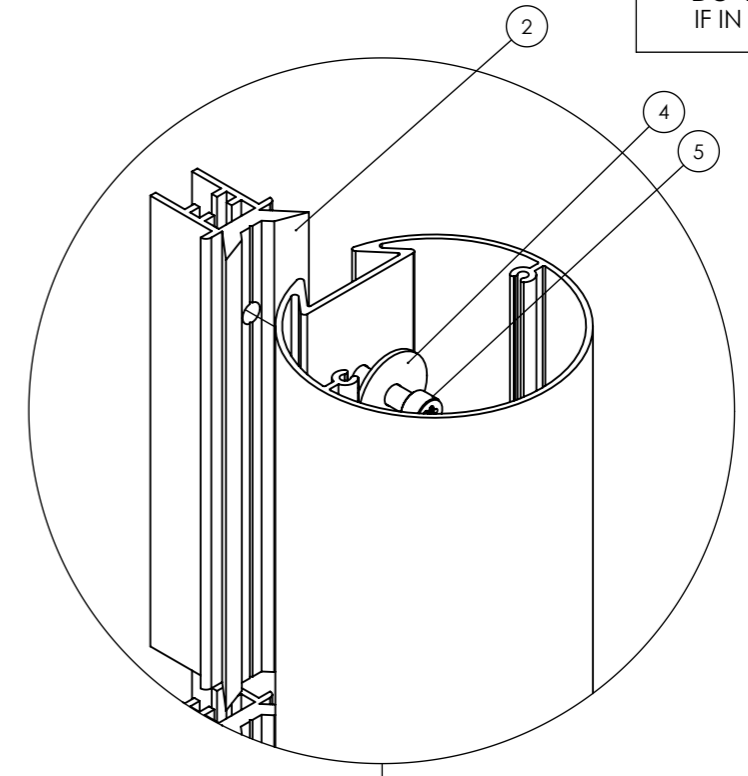

DETAIL B
SCALE 1:2

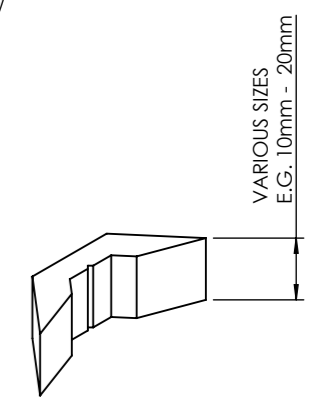

DETAIL D
SCALE 1:1

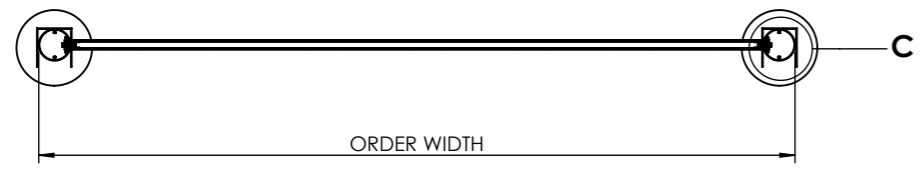

SECTION A-A

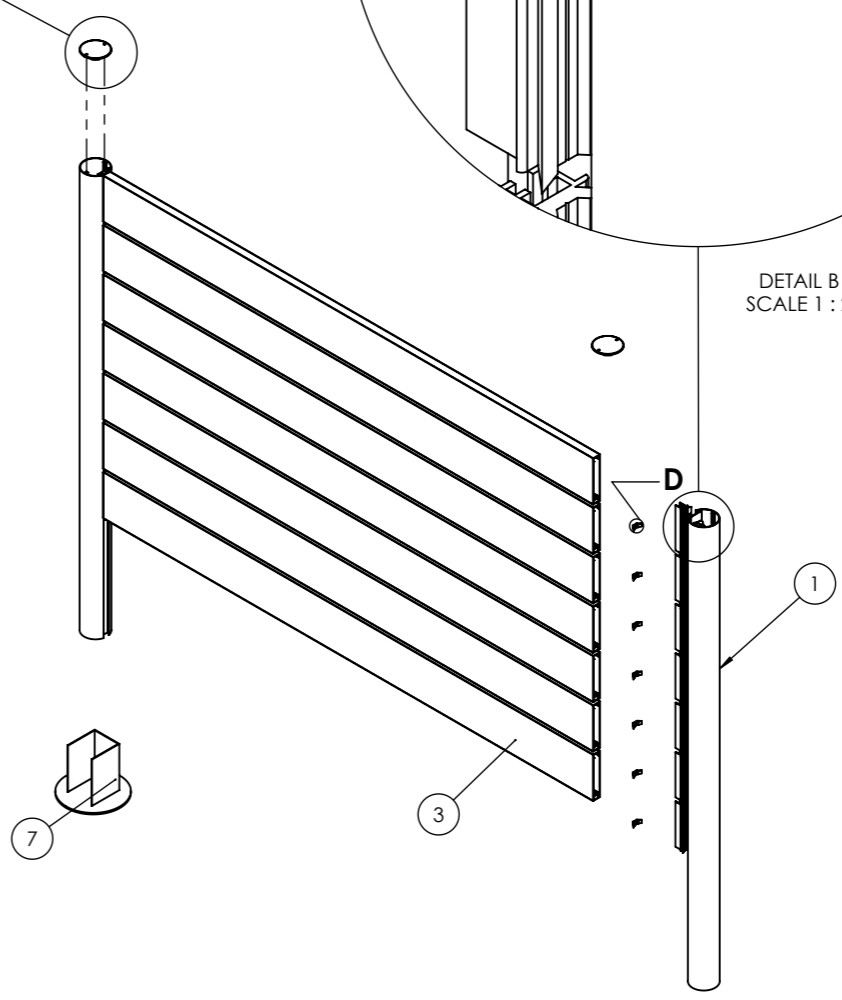

EXPLODED VIEW OF EQUIPMENT SUPPLIED
SCALE 1:20

BILL OF MATERIALS SIGN POLE 84 ASSEMBLY

ITEM NO.	DRAWING No/REF	QTY	FINISH	NOTES
1	SIGN POLE 84	2		
2	PROFILE B	2 No PER DATAPLANK		
3	150mm DATAPLANK	AS REQ'		100mm VERSION ALSO OPTION
4	WASHER	2		SIZE TBC
5	M6 TORX CAP SCREW	2		
6	SIGN POLE 84 CAP	2		
7	POST FOOT	2		
8	DELTA FIX	2 No PER DATAPLANK		

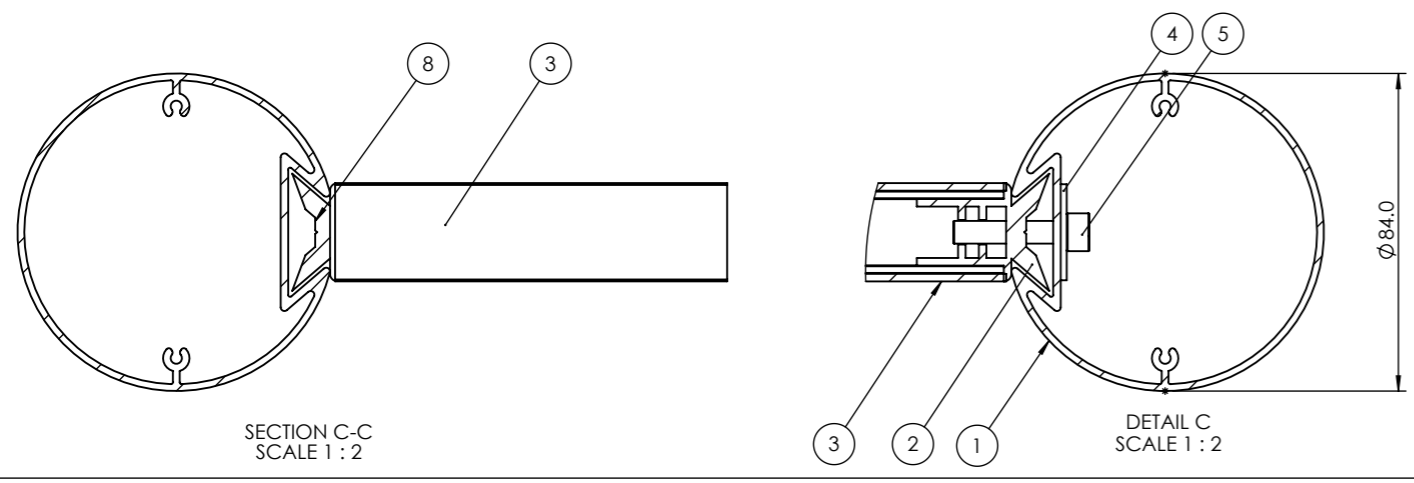

SECTION C-C
SCALE 1:2

DETAIL C
SCALE 1:2

REV.	DATE	DESCRIPTION	BY

THIS DRAWING IS THE PROPERTY OF KSUK LTD AND MAY NOT BE REPRODUCED OR TRANSMITTED IN ANY FORM OR BY ANY MEANS WITHOUT THE EXPRESS WRITTEN CONSENT OF THE COMPANY BEING USED FOR ANY OTHER PURPOSE THAN THAT FOR WHICH IT IS SUPPLIED

GENERAL TOLERANCES UNLESS OTHERWISE STATED:
 0 DECIMAL PLACES +/- 1mm
 1 DECIMAL PLACE +/- 0.5mm
 2 DECIMAL PLACES +/- 0.15mm
 ANGULAR DIMENSIONS +/- 1/2°

KSUK[®]

T 0121 783 0779, F 0121 783 1334
 KSUK, Unit 6 Valepits Road, Garrets Green Industrial Estate, Birmingham, West Midlands, B33 0TD

DRAWING TITLE: SIGN POLE 84		
PRODUCT RANGE: DATAPLANK		
PROJECT No: IDS-236	DATE: 28-01-19	
PAPER: A3	DRAWN: R.L	CHKD: -
SCALE: N.T.S	DWG No.: IDS-236-015	REV: -