

Step 3

Prespacers Fitting Sequence

Only after the Prespacers A-F have been attached should any attempt be made to attach the SPRINGS. Using the Prespacers first will ensure the face fits exactly as it should be, in its final position centred on the sign face in the quickest possible time. When all the Prespacers are holding the face in position, USING THE HOOK PULLER SUPPLIED, attaching SPRING Nos 1, 2 and 3 into the punched holes ensuring the hook goes over the tension bar each time, then continue attaching springs in a clockwise manner all springs in sequence.

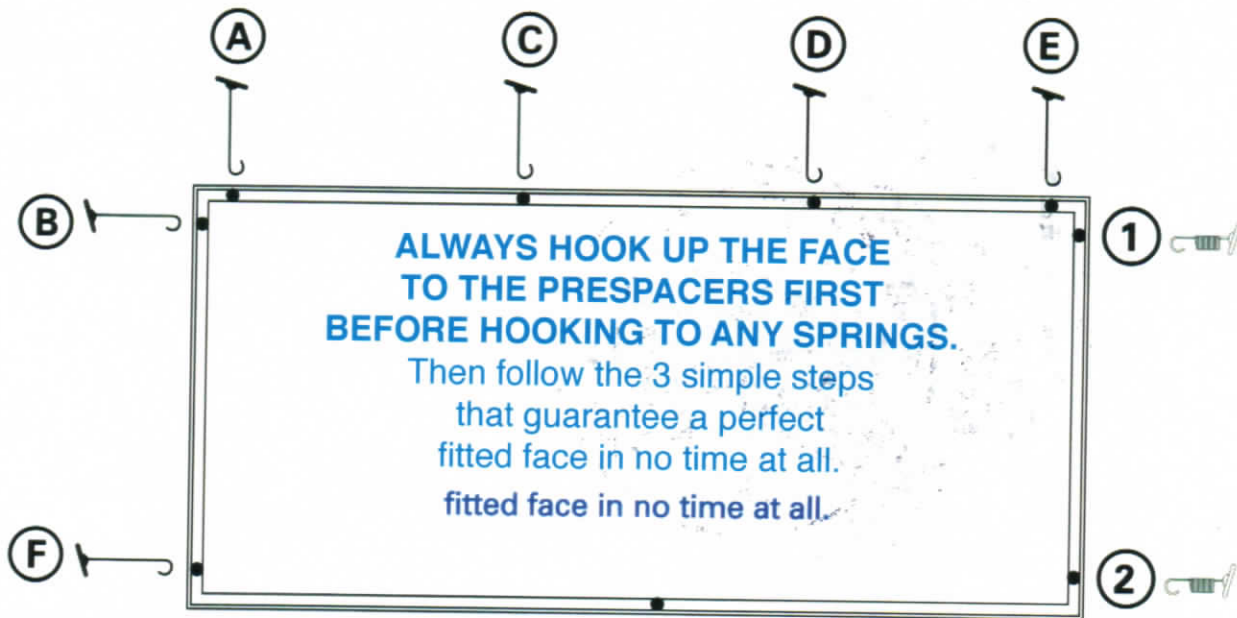

Installer Tip

Have someone positioned about 1 - 2 mtrs ahead of the spring installer pulling the face straight as the springs are fitted.

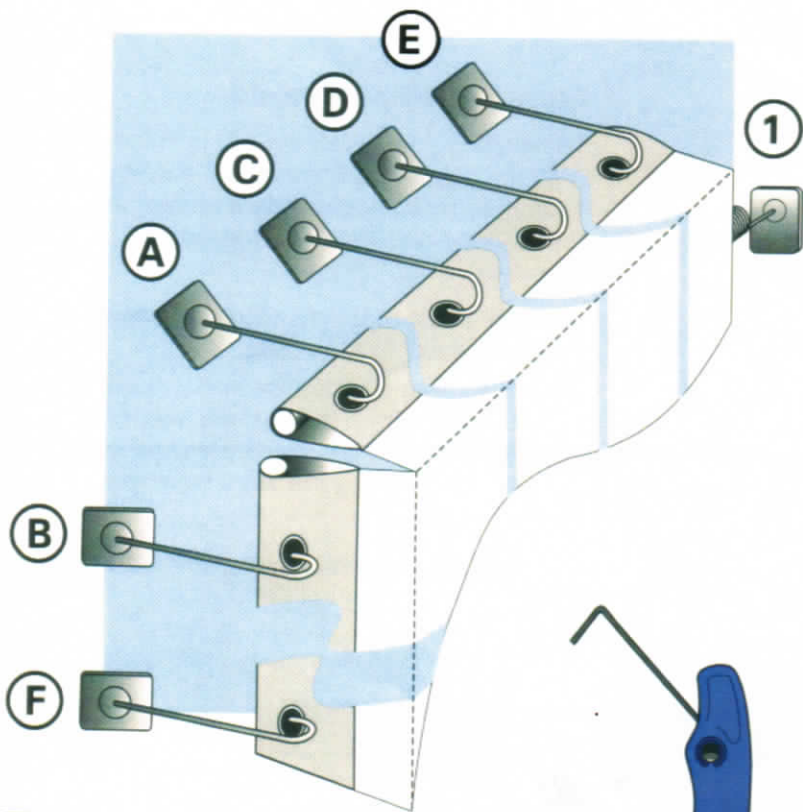

Maintenance Kit

Spare Prespacers, Springs and Hook Puller can be purchased as a kit. Reference No. MK056

Spring Replacement

Insert replacement Spring into slide channel of the profile then rotate the Spring 90 degrees.

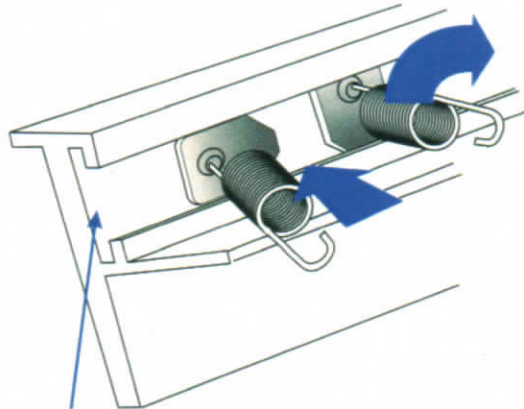

Spring's slide channel

Errors in the installation or sign face materials can create problems and overstretch springs. Refer to installation notes.